

STRICTLY CONFIDENTIAL

For Philips
Service Dealers only
Copyright

Published by
THE CENTRAL SERVICE DIVISION
N.V. Philips' Gloeilampenfabrieken
Eindhoven

PHILIPS

SERVICE NOTES

for the radio-gramophone

FX 637A

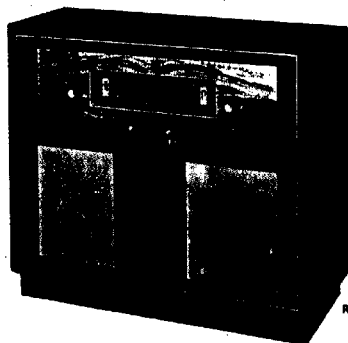

R15076

1953

For A.C. mains supply

GENERAL

Waveranges:

S.W.2a :	11.4 - 20	m	{	26.3 - 15	Mc/s
S.W.2 :	20 - 59.5	m	{	15 - 5.05	Mc/s
S.W.3 :	59 - 187	m	{	5.1 - 1.6	Mc/s
M.W. :	185 - 580	m	{	1622 - 517	kc/s

I.F. : 452 kc/s

Mains voltage:

90 - 110 - 125 - 180 -
200 - 220 V a.c.

Controls:

(From left to right)

- 1a (large knob):
Mains switch and volume control
- 1b (small knob):
Tone control
- 1a+1b (push and pull):
Bas switch
- 2 (Lever):
Switch for frame aerials
- 3a (large knob):
Waverange- and p.u. switch
- 3b (small knob):
Tuning.

Consumption:

Approx.: 57 W (220 V
a.c.) without motor
Approx.: 67 W (220 V
a.c.) with motor running

Loudspeaker:

9750-05 ($Z = 5 \Omega$)

Record-changer:

A.G. 1000

P.U. head:

A.G. 3010

Bandwidth:

The I.F. bandwidth (1:10)
measured from g1 of B2 is
about 10.5 kc/s. The
"overall" bandwidth (1:10)
measured from the aerial
socket at 1000 kc/s is
about 9 kc/s and about
8.5 kc/s at 550 kc/s.

Valves:

B1 : EF41
B2 : ECH81
B3 : EBF80
B4 : EBC41
B5 : EL84
B6 : EZ80
B7 : 6X4
B8 : EBC41

Dimensions:

Length : 92 cm) knobs
Depth : 39 cm) in-
Height : 78 cm) cluded.

Weight: 58 kg.

Diallamps:

L1 : 8045D-00
L2 : 8045D-00
L3 : 8045D-00
L4 : 8045D-00

Printed in Holland

93 979 58.1.05

- Fig. 1 : R.F. and oscillator circuit for each position of the waverange switch.
- Fig. 2 : Location of trimming points on the dial.
- Fig. 3 : Cable-drive.
- Fig. 4 : Switch-wafers and coil connections.
- Fig. 5 : Circuit diagram.
- Fig. 6 : Wiring diagram (under).
- Fig. 7 : Wiring diagram (above).
- Fig. 8 : Wiring in the cabinet.
- Fig. 9 : Mains transformer.
- Fig. 10 : P.U. amplifier-unit.

TRIMMING THE RECEIVER

A. The I.F. Part.

1. Set the waverange-switch to M.W.
2. Turn the variable capacitor to minimum capacity.
3. Set the volume control to maximum.
4. Unscrew the I.F. ironcores almost entirely.
5. Connect a voltmeter via a trimming transformer to the extension loudspeaker socket.
6. Apply to g1 of B2 a modulated signal of 452 kc/s, via a capacitor of 33000 pF.
7. Trim the I.F. circuits in the following order:

4th I.F. circuit	S36 - C48	(coil N)
3rd I.F. circuit	S34 - C47	(coil N)
1st I.F. circuit	S30 - S31 - C44	(coil M)
2nd I.F. circuit	S32 - S33 - C45	(coil M)
3rd I.F. circuit	S34 - C47	(coil N)

8. Seal the cores.

Note: The iron cores of the I.F. bandfilters have been sealed with "Vaseline compound" (See list of parts and tools). This compound can easily be removed in the cold state with the aid of a screw-driver. Heating of the core damages the core holder and makes trimming impossible.

B. R.F. and oscillator circuits.

Trimming is done with the aid of trimming points on the dial (See fig. 2). There is no need to take the chassis out of the cabinet. Before starting to trim, check the adjustment of the pointer. With the variable capacitor at minimum, the pointer must be on the extreme left trimming mark on the dial. If not, release the pointer from its cable and adjust it to the correct position.

For all waveranges the following applies:

1. Volume control to maximum.
2. Tone control in the mellow position.
3. Connect a voltmeter via a trimming-transformer to the extension loudspeaker socket.

Trim as indicate in the following table, strictly observing the order given:

1	Waverange switch in position	M.W.	S.W.3	S.W.2	S.W.2a
2	Screw fully in	-	-	-	S6 S13
3	Switch SK4 into position	ant.	-	-	-
4	Pointer on trimming point by means of tuning knob	2	2	2	2
5	Apply modulated signal of to aerial socket via normal dummy aerial	550 kc/s	1.72 Mc/s	5.41 Mc/s	15.24 Mc/s
6	Trim for maximum output voltage	S29 S18 S12	S27 S15 S10	S25 S14 S8	S22 S13 S6
7	Pointer on trimming point by means of tuning knob	1	1	1	1
8	Apply modulated signal of to aerial socket via normal dummy aerial.	1630 kc/s	5.15 Mc/s	15.1 Mc/s	26.4 Mc/s
9	Trim for maximum output voltage	C29 C14 C8	C28 C13 C7	C25 C12 C6	C54
10	Repeat the points	4-9	4-9	4-9	4-9
11	Seal the cores and trimmers	S29 S18 S12 C29 C14 C8	S27 S15 S10 C28 C13 C7	S25 S14 S8 C25 C12 C6	S22 S13 S6 C54

REPAIRS AND REPLACEMENTS

Removing the record-changer from the cabinet.

1. Remove the large wooden rearpanel (19 screws).
2. Slide the record-changer out of the cabinet.
3. Lift the record-changer out of the wooden case and release the connections from the blocks II and III (See fig. 8).

Removing the chassis from the cabinet.

1. Remove the rear panel.
2. Release the connections from blocks I, IV and V (See fig. 8).
3. Remove the male connecting plate from SK4.
4. Unscrew the 2 wood screws, on the shelf behind the dial.

5. Unscrew the 4 cylindrical screws with the aid of which the mounting shelf under the chassis is fixed in the cabinet.
6. Remove the knobs and take the chassis, with mounting shelf and dial out of the cabinet.

Cable drive.

The path and the lengths of the cables are indicated in fig. 3, the variable capacitor being set to maximum capacity.

A. Capacitor drive (cord A-B)

1. Remove the chassis from the cabinet.
2. Remove the large cable drum (3 screws).
3. Remove the broken cord.
4. Assemble the new cord "A-B".
5. Push the nipple "c" of the cord "A-B" in the slit "c" of the small drum.
6. Turn the drum till the slit "c" is at 5 o'clock.
7. Fasten the drum with a nail.
8. Pass the end "B" $3/4$ x in a clockwise direction around the drum and $2\frac{1}{2}$ x in a clockwise direction around the tuning spindle.
9. Place the cable guide in position.
10. Pass the cord around the pulley and the capacitor drum and fix it temporarily with a crocodile clip.
11. Pass the end "A" $1\frac{3}{4}$ x in an anti-clockwise direction around the drum and $2\frac{1}{2}$ x in an anti-clockwise direction around the tuning spindle.
12. Place the cable guide in position.
13. Pass the cord around the capacitor drum.
14. Hook the spring in the cordloops, pass the ends through the drum opening and lay the ends in the right direction around the pin of the drum.
15. Fix the spring on its bracket and remove the crocodile clip.
16. Remove the nail and replace the large cable drum.

B. Pointer drive (cables C and D)

1. Remove the chassis from the cabinet.
2. Remove the broken cable(s).
3. Assemble the new cable(s).
4. Push the nipple "a" of the cable "D" in the slit "a" of the cable drum, pass the cable 3 x in an anti-clockwise direction around the drum and the pulleys and fix it temporarily with a crocodile clip to any convenient point.
5. Push the nipple "b" of the cable "C" in the slit "b", pass the cable $1\frac{1}{2}$ x in a clockwise direction around the drum.
6. Connect the both cable ends by means of the spring and remove the crocodile clip.

Cable drive for volume control (cable H)

The path and the length of the cable are indicated in fig. 3.

1. Remove the chassis from the cabinet.
2. Remove the broken cable.
3. Assemble the new cable.
4. Turn the mains switch in position "off".

5. Turn the drum no 1 till the hole "b" is to the left (see the illustration) and fasten the drum with a nail.
6. Pass the end "h1" through the hole "b" of the drum no 1, the end "h2" through the hole "c" and both ends through the hole "e".
7. Pass the end "h1" $1 \frac{1}{4}$ x in a clockwise direction around the drum no 1 and then through the hole "a" of the drum no 2.
8. Push a nipple over the cable, pull the cable tight and fix the cable by means of the nipple.
9. Pass the end "h2" $1 \frac{1}{4}$ x in an anti-clockwise direction around the drum no 2 and then through the hole "d".
10. Push a nipple over the cable, pull the cable tight and fix the cable by means of the nipple.
11. Remove the nail.

Cable drive for the tone control (cable G)

The path and the length of the cable are indicated in fig. 3.

1. Remove the chassis from the cabinet.
2. Remove the broken cable.
3. Assemble the new cable.
4. Turn the tone control (drum no 4) in position "low notes" (see the illustration).
5. Turn the drum no 3 till the hole "b" is to the left (see the illustration) and fasten the drum with a nail.
6. Pass the end "g1" through the hole "b" of the drum no 3, the end "g2" through the hole "c" and both ends through the hole "e".
7. Pass the end "g1" $1 \frac{1}{4}$ x in a clockwise direction around the drum no 3 and then through the hole "a" and the hole "g" of the drum no 4.
8. Push a nipple over the cable, pull the cable tight and fix the cable by means of the nipple.
9. Pass the end "g2" $1 \frac{1}{4}$ x in an anti-clockwise direction around the drum no 3 $1 \frac{1}{2}$ x in an anti-clockwise direction around the drum no 4 and then through the hole "d" and the hole "f".
10. Push a nipple over the cable, pull the cable tight and fix the cable by means of the nipple.
11. Remove the nail.

Mains transformer

If the original mains transformer of this apparatus becomes defective, it must be replaced by the standard transformer mentioned in the electrical parts list.

If a mains tension of 180 Volts must be applied to the set, equipped with the standard transformer, it must be applied to the points 1A and 5 of this transformer. In case, the standard transformer has been replaced, the voltage adaptor, mentioned in the list of parts and tools, should also be replaced.

For connections see fig. 9

CURRENTS AND VOLTAGES

Valves			Va	Vg2(+4)	Vk	Ia	Ig2(+4)
B1	EF41	Pentode	218	80	1.2	2.8	0.7
B2	ECH81	Hexode	246	80	-	2.0	4.7
		Triode	105	-	-	4.3	-
B3	EBF80	Pentode	246	80	-	5.0	1.6
B4	EBC41	Triode	90	-	-	0.58	-
B5	EL84	Pentode	245	242	7.5	45	4.8
B8	EBC41	Triode	225	-	1.2	0.7	-
			Volts	Volts	Volts	mA	mA

VC1 = 270 V

VC2 = 246 V

I prim = 255 mA (220 V a.c.)

These measurements have been taken with the Universal Measuring Instrument GM 4257 with the receiver connected to 220 V a.c. and no signal on the aerial socket.

LIST OF PARTS AND TOOLS

When ordering always quote:

1. Code number.
2. Description.
3. Type number of the set.

	Description	Code number
	Spring (2x)	A3 644 34.0
	Rear panel	A3 255 67.0
	Rubber grommet fixing chassis (4x)	A3 642 18.0
	Waverange indication disc	A3 406 90.0
	Ornamental window for waverange indicator	A3 360 61.0
	Ornamental window for tuning indicator	A3 360 54.0
	Bas switch	A3 186 67.0
	Nut for fixing potentiometers	49 758 21.0
	Small cable drum (colour AA)	23 644 75.0
	Intermediate wheel	P4 120 03.0
	Large cable drum (colour AA)	23 644 47.2
	Variable capacitor	see capacitors
	Spring in drum var. capacitor	A3 646 57.0
	Spring in pointer cable	A3 646 14.0
	Connecting plate	A3 382 13.0
	Valve holder (4x)	B1 505 20.0
	Spring for fixing coilcans (5x)	A3 652 58.3
	Voltage adaptor	A3 228 81.0
	Dial lamp holder (1x)	A3 359 16.1
	Valve holder (tuning indicator)	B1 506 70.0
	Spring for fixing coilcan (1x)	A3 652 92.0
	Cable drum on waverange switch spindle	P4 380 02.0
	Dial lamp holder (2x)	A3 359 16.1
	Spring for fixing record-changer	49 933 87.0
	Center plate above this spring	49 935 66.0
	Switch wafer for SK4	A3 192 32.0
	Spindle for potentiometers	A3 432 95.0
	Knob (volume control and waverange switch (2x)	A3 736 07.0
	Knob (tuning)	A3 735 55.0
	Knob (tone control)	A3 735 55.0
	Dial (Mediterranean)	A3 741 23.0
	Dial (overseas)	A3 741 24.0
	<u>Tools</u>	
	Service oscillator	GM 2883 or GM 2883/02 or GM 2884
	Universal Measuring Instrument	GM 4257
	Vaseline Compound	X 009 47.0
	JvE/MZ	

S1				C7	30	pF	28 212 36.4
S2				C8	10	pF	49 005 64.1
S3			A3 141 37.5	C9	330	pF	A9 999 04/330E
S5	1.3	Ω		C10	180	pF	A9 999 04/180E
S6	< 1	Ω	A3 125 25.0	C11	150	pF	A9 999 04/150E
S7	< 1	Ω		C12	20	pF	49 005 59.3
S8	< 1	Ω	A3 125 29.0	C13	30	pF	28 212 36.4
S9	8.6	Ω		C14	20	pF	49 005 59.3
S10	1.6	Ω	A3 125 33.0	C15	150	pF	A9 999 04/150E
S11	< 1	Ω		C16	68	pF	A9 999 04/68E
S12	< 1	Ω	A3 117 04.0	par.)	100	pF	A9 999 04/100E
S13	< 1	Ω	A3 125 38.0	C17	100	pF	A9 999 04/100E
S14	< 1	Ω	A3 125 42.0	C18	39	pF	A9 999 04/39E
S15	1.6	Ω		C19	0.22	μF	A9 999 06/220K
S16	1.6	Ω	A3 125 46.0	C20	2200	pF	A9 999 06/2K2
S17	40	Ω		G21	160	pF	A9 999 05/160E
S18	3	Ω	A3 125 35.0	G22	220	pF	A9 999 04/220E
S19	30	Ω	A3 110 66.0	G23	56	pF	A9 999 04/56E
S20	2.5	Ω		G24	100	pF	A9 999 04/100E
S21	< 1	Ω		G25	30	pF	28 212 36.4
S22	< 1	Ω	A3 125 50.0	G26	1500	pF	A9 999 05/1K5
S23	< 1	Ω		par.)	47	pF	A9 999 05/47E
S24	< 1	Ω	A3 125 58.0	G27	330	pF	A9 999 05/330E
S25	< 1	Ω		par.)	47	pF	A9 999 05/47E
S26	1	Ω		G28	30	pF	28 212 36.4
S27	2.6	Ω	A3 125 68.0	G29	20	pF	49 005 59.3
S28	2.6	Ω		C30	1500	pF	A9 999 04/1K5
S29	6	Ω	A3 125 93.0	C31	3000	pF	A9 999 05/3K
S30	4.5	Ω		C44	see coils		
S31	3	Ω		C45	voir bobines		
S32	4.5	Ω		C46	10	pF	A9 999 04/10E
S33	3	Ω	A3 121 94.2	C47	see coils		
C44	115	pF		C48	voir bobines		
C45	115	pF		C49	82	pF	A9 999 04/82E
S34	10	Ω		C50	47000	pF	A9 999 06/47K
S36	10	Ω		C51	18	pF	A9 999 04/18E
C47	110	pF	A3 124 25.4	C52	10000	pF	A9 999 06/10K
C48	110	pF		C54	30	pF	28 212 36.4
S40	400	Ω		C58	39	pF	A9 999 04/39E
S41	400	Ω		C59	18	pF	A9 999 04/18E
S42	< 1	Ω	A3 169 57.0	C61	10000	pF	A9 999 04/10K
S43	< 1	Ω		C62	2200	pF	A9 999 06/2K2
C1	50	μF		C63	33000	pF	A9 999 06/33K
C2	50	μF	48 317 59/50+ 50	C64	22000	pF	A9 999 06/22K
C3	11-498	pF		C66	3300	pF	A9 999 05/3K3
C4	11-498	pF	49 001 76.0	C67	10000	pF	A9 999 06/10K
C5	11-498	pF		C69	22000	pF	A9 999 06/22K
C6	20	pF	49 005 59.3	C71	2200	pF	A9 999 06/22K2
				C72	1500	pF	A9 999 04/1K5
				C73	0.1	μF	A9 999 06/100K
				C76	2200	pF	A9 999 06/2K2
				C77	0.1	μF	A9 999 06/100K
				C100	330	pF	A9 999 04/330E
				C101	1000	pF	A9 999 06/1K
				C102	10000	pF	A9 999 06/10K
				C103	15	pF	A9 999 04/15E

C110	50	μ F	AC 5540/50	R46	0.05 M Ω	48 900 00/GL
R1	1000	Ω	49 379 81.0	R47	0.45 M Ω	50K + 450K x)
R2	0.1	M Ω	A9 999 00/100K	R49	1.5 M Ω	A9 999 00/1M5
R3	10000	Ω	A9 999 00/10K	R50	0.47 M Ω	A9 999 00/470K
R4	1000	Ω	A9 999 00/1K	R51	1.5 M Ω	A9 999 00/1M5
R5	0.82	M Ω	A9 999 00/820K	R52	10 M Ω	A9 999 00/10M
R6	2x 47000	Ω par	A9 999 00/47K	R53	6.8 M Ω	A9 999 00/6M8
R7	4700	Ω	A9 999 00/47K	R55	0.47 M Ω	A9 999 00/470K
R8	33000	Ω	A9 999 00/33K	R56	22 Ω	A9 999 00/22E
R9	10000	Ω	A9 999 00/10K	R57	0.1 M Ω	A9 999 00/100K
R10	330	Ω	A9 999 00/330E	R80	1 M Ω	A9 999 00/1M
R11	1	M Ω	A9 999 00/1M	R81	1 M Ω	A9 999 00/1M
R12	1.2	M Ω	A9 999 00/1M2	R82	6.8 M Ω	A9 999 00/6M8
R13	47000	Ω	A9 999 00/47K	R83	1800 Ω	A9 999 00/1K8
R17	2.2	M Ω	A9 999 00/2M2	R84	1 M Ω	A9 999 00/1M
R27	220	Ω	A9 999 00/220E	R85	68000 Ω	A9 999 00/68K
R28	0.82	M Ω	A9 999 00/820K	R86	0.47 M Ω	A9 999 00/470K
R29	0.1	M Ω	A9 999 00/100K	R87	0.22 M Ω	A9 999 00/220K
R30	15000	Ω	A9 999 00/15K	x)	See list of parts and tools	
R31	0.45	M Ω	48 900 00/DL		Voir liste des pièces détachées	
R32	0.05	M Ω	50K + 450K x)		et outils	
R33	10	M Ω	A9 999 00/10M			
R34	0.12	M Ω	A9 999 00/120K			
R38	47000	Ω	A9 999 00/47K			
R42	1000	Ω	A9 999 00/1K			
R44	150	Ω	A9 999 00/150E			
R45	820	Ω	49 380 13.0			
					JvE/MZ	

FX 637 A

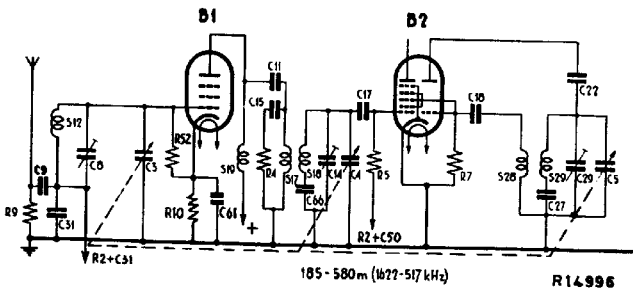
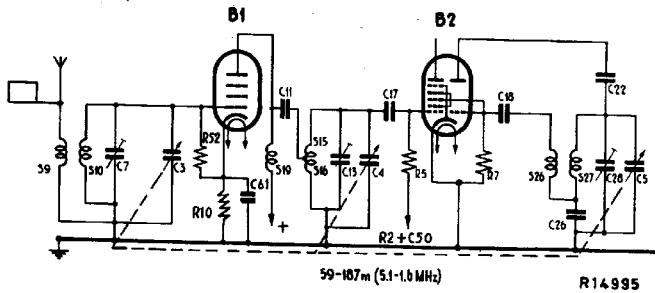
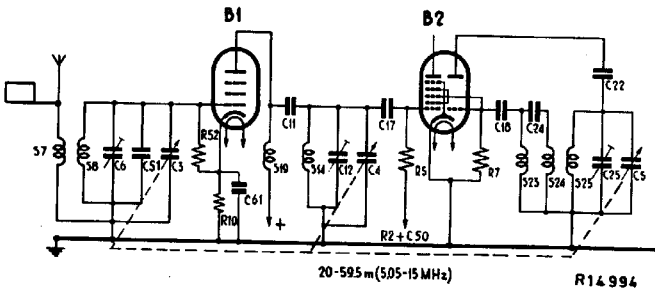
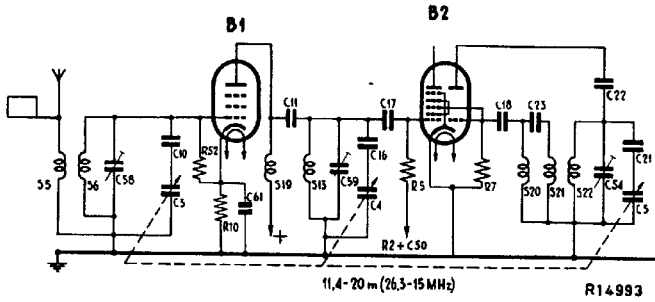
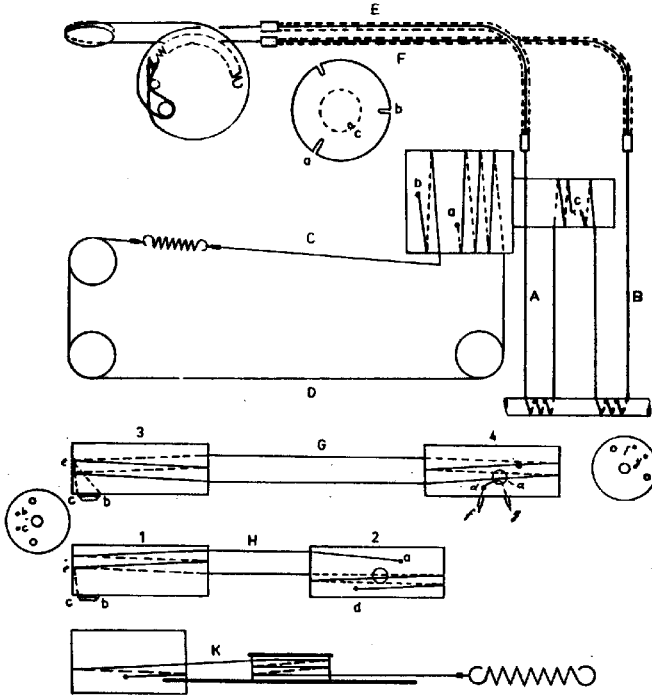
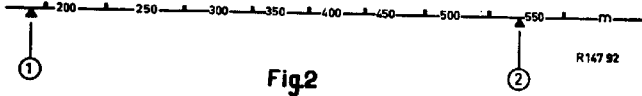
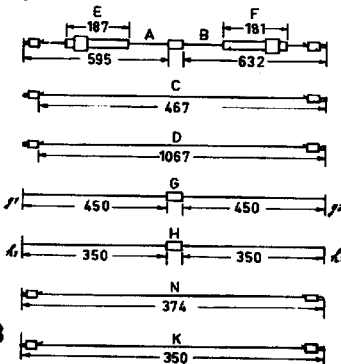

Fig.1



- A = 595 mm
- B = 632 mm
- C = 467 mm
- D = 1067 mm
- E = 187 mm
- F = 181 mm
- G = 900 mm
- H = 700 mm
- N = 374 mm
- K = 350 mm

Fig.3



FX 637A

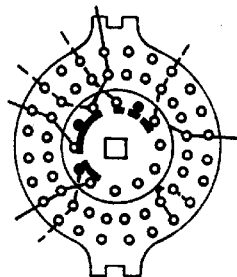
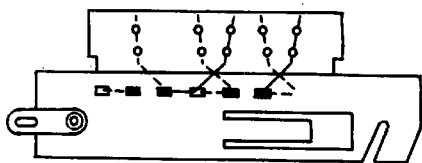
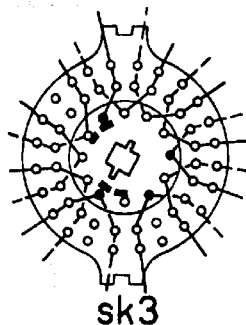
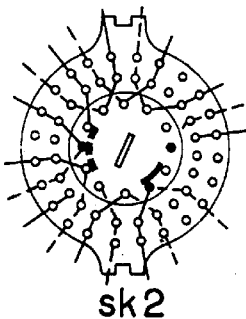
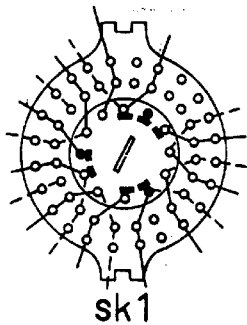

R15074

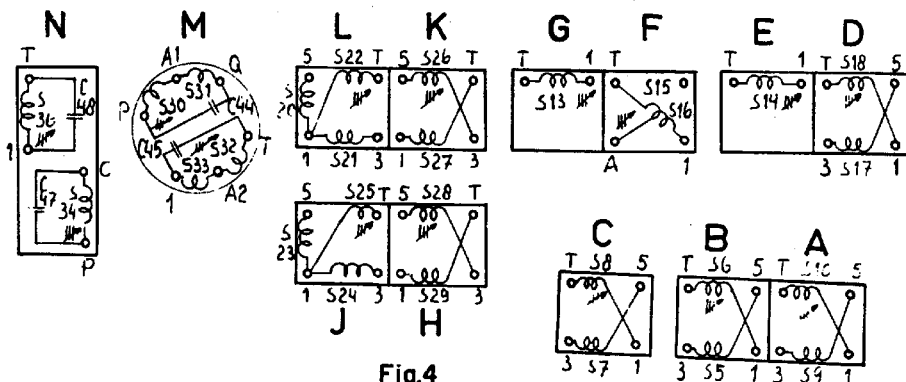
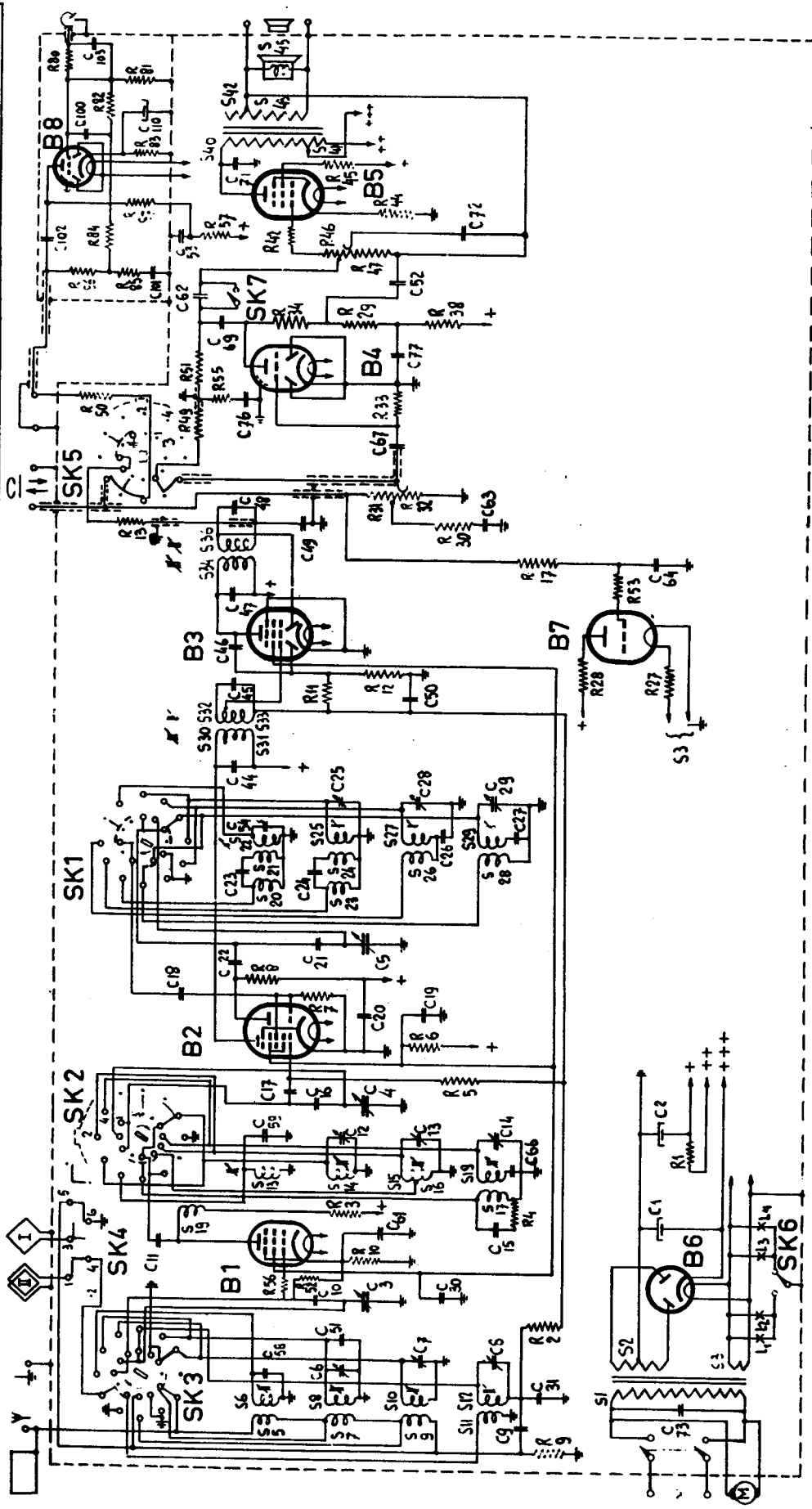

Fig.4

S:1.2.3. 5. 6. 7. 8. 9. 10. 11. 12.	19. 13. 14. 15. 16. 17. 18.	20. 21. 22. 23. 24. 25. 26. 27. 28. 29. 30. 31. 32. 33.	34. 36.	40. 41. 42. 43.	45.
C: 7. 3. 9. 31. 58. 6. 7. 8. 51.	10. 3. 30.	11. 61. 15. 1. 65. 59. 12. 13. 14. 2. 16. 17. 20. 19. 18. 22. 21. 52. 23. 24.	45. 50. 46.	47. 64. 48. 49. 63.	67. 76. 77.
R: 9.	2.	56. 52. 10. 34.	5.	6. 7. 8.	49. 33. 51. 55.
					34. 29. 28. 46. 47. 86. 8. 5. 57. 42. 84. 87. 44. 4. 5. 9. 3. 82. 8. 1. 80.



R15069

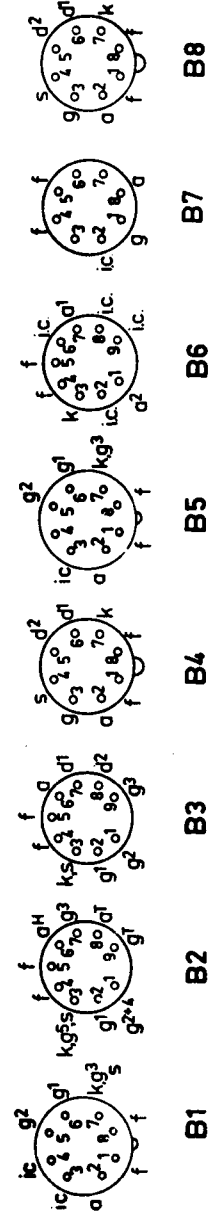

Fig.5

FX 637 A

S:	62.	71.	72.52	77.	69.63	67.	81.	N	7.	22.17.	6.	21.60	51.	52.12.24.50.58.66.61	31.60.61.62.63.64.65.66.67.68.69.70.71.72.73.74.75.76.77.78.79.80.81.82.83.84.85.86.87.88.89.90.91.92.93.94.95.96.97.98.99.100.
C:	62.	71.	72.52	77.	69.63	67.	81.	N	7.	22.17.	6.	21.60	51.	52.12.24.50.58.66.61	31.60.61.62.63.64.65.66.67.68.69.70.71.72.73.74.75.76.77.78.79.80.81.82.83.84.85.86.87.88.89.90.91.92.93.94.95.96.97.98.99.100.
R:	46.47.	45.	42.30.30.4.27.29.4.32.31.	33.	51.	55.50.8.8.9.9.12.28.46.71.	7.	5.	13.49.	50.	4.	10.	52.	3.	2.

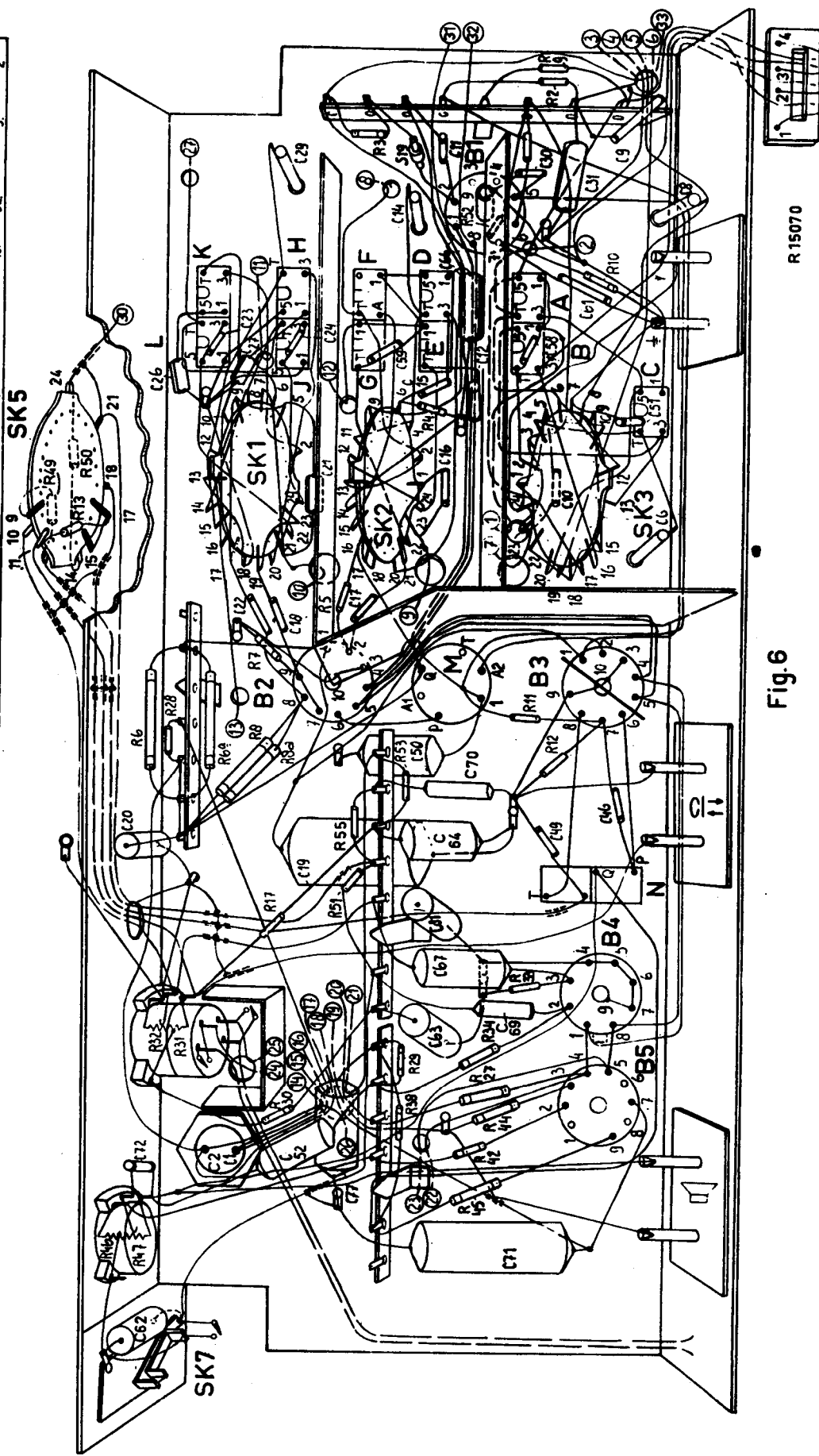

Fig.6

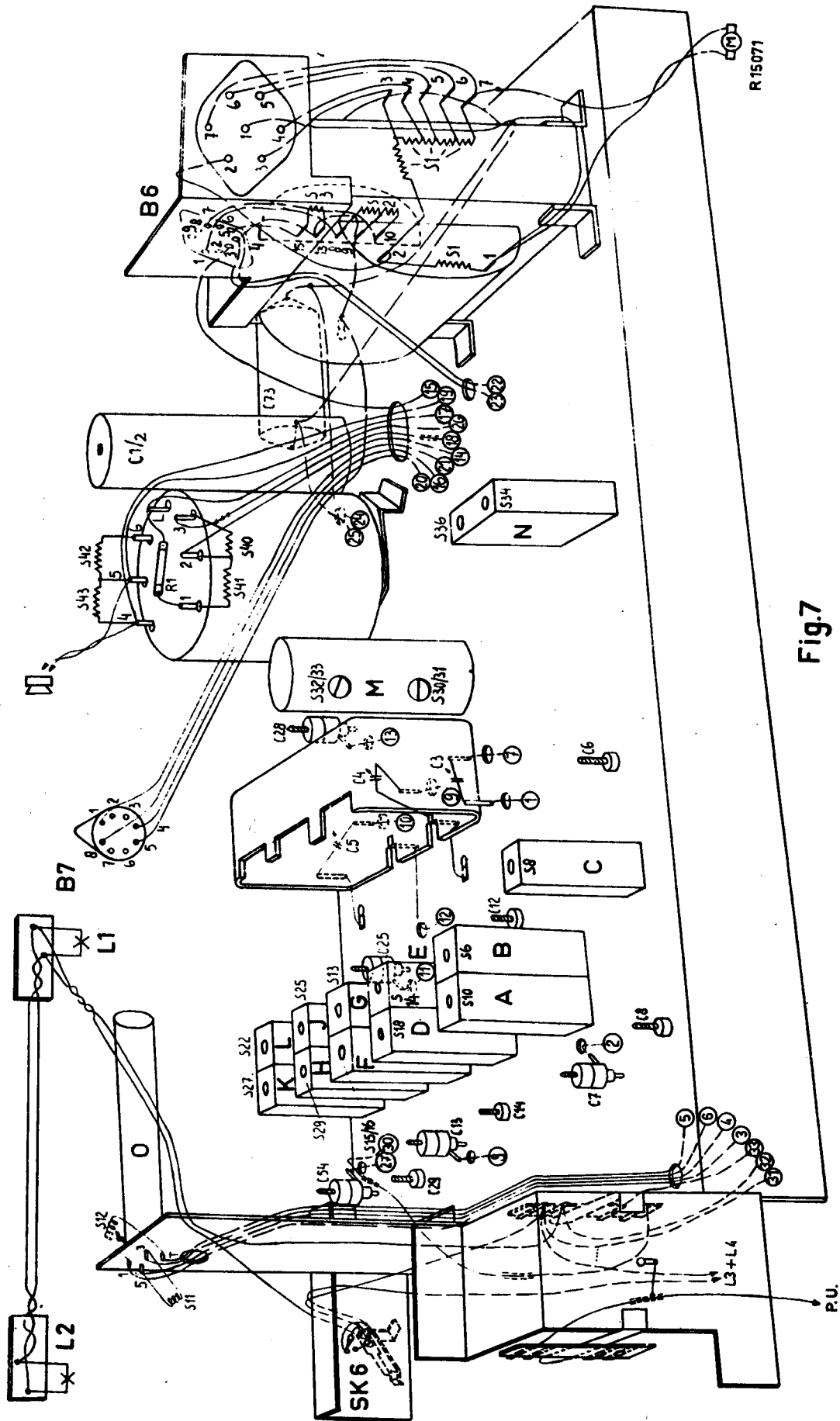

Fig.7

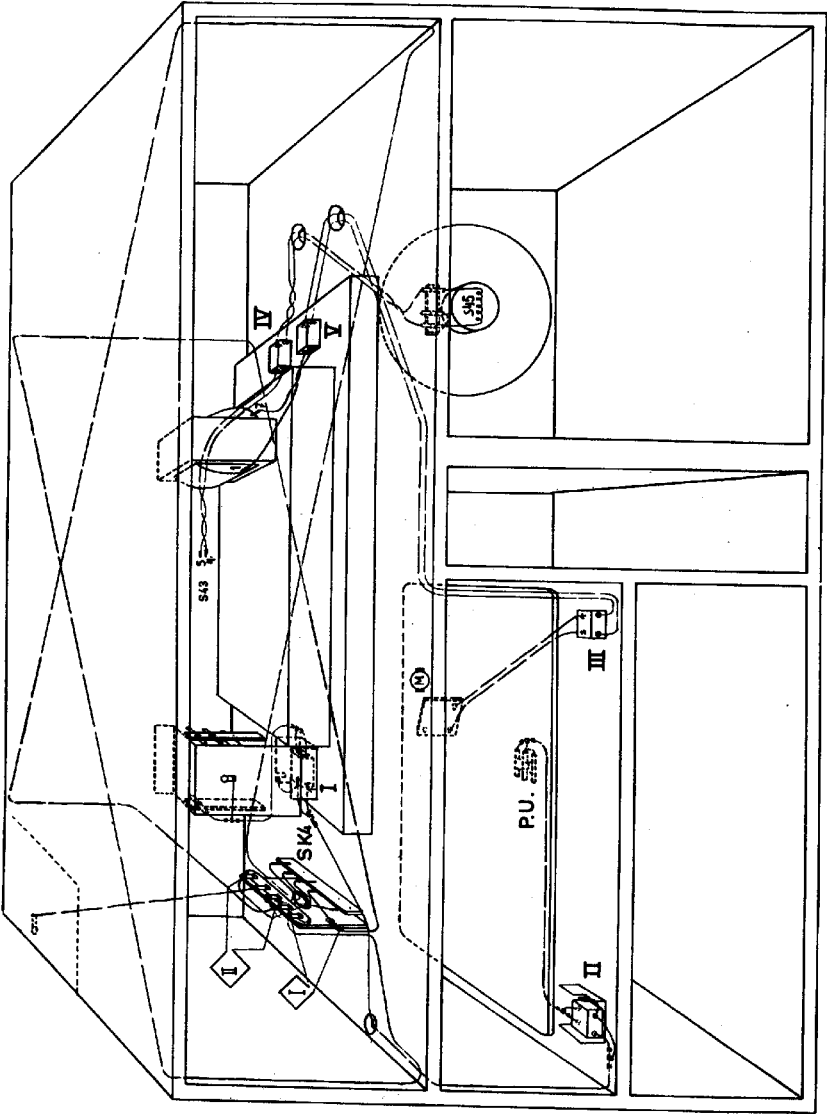
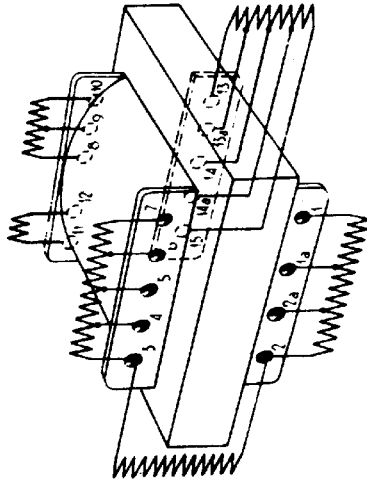

Fig. 8

R15072



R14991



Fig.9

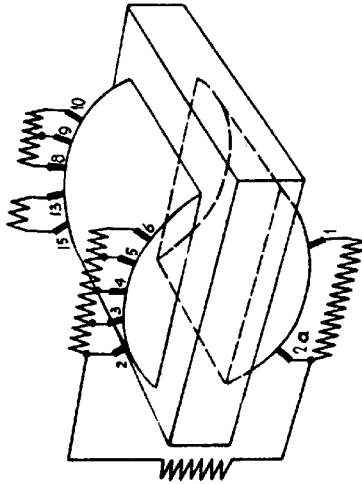

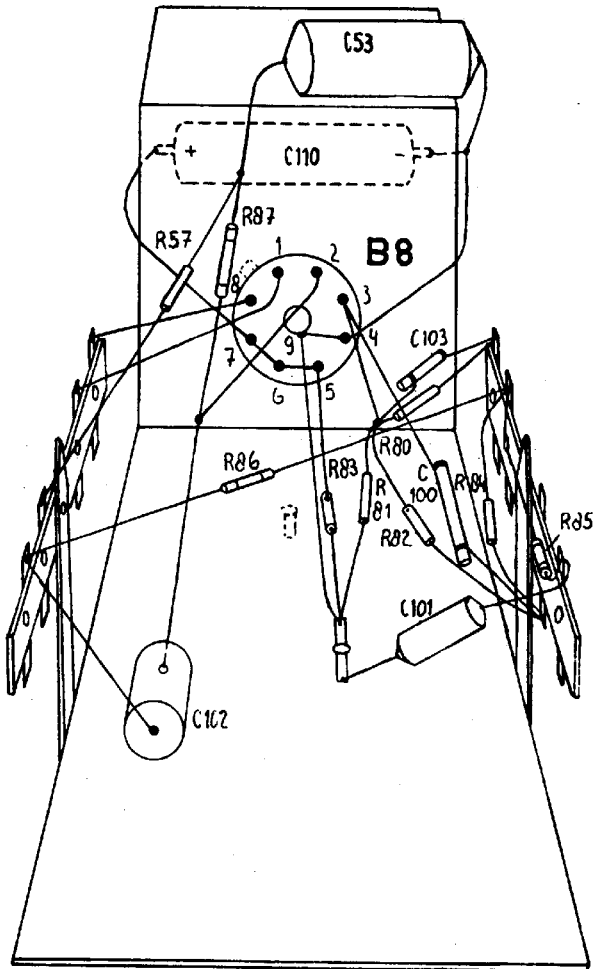

Fig.10

R15075